

MURPHY TA222

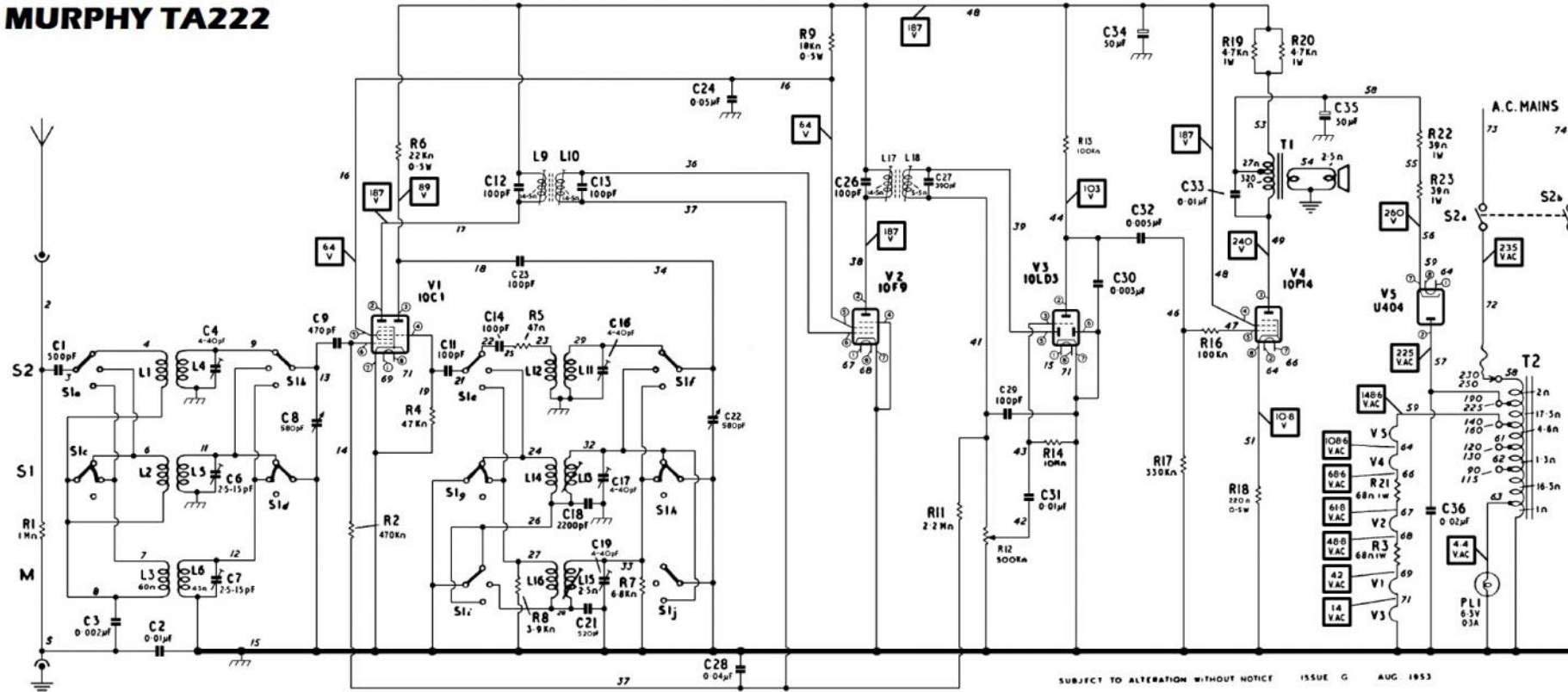

In later sets, R22 and R23 are deleted and replaced by one 180Ω, 6W, wire wound resistor Part No. 51082. This resistor is located on the top of the chassis in front of V5.

Circuit voltages are shown within squares and were measured between chassis and the point indicated using a 20,000 Ω/V meter while the receiver was switched to the M band under no-signal conditions.

Where the resistance of a coil is less than 1 ohm the value is omitted.

Component terminals and connecting leads are identified by test point (t.p.) numbers which correspond with those appearing on the chassis drawings. The valve pin numbers are shown within small circles. All the valves are Ediswan or Mazda types. Alternative valves: V2 — Mullard UF41 V3 — Mullard UBC41